

Clinical and Molecular Findings in a Moroccan Family with Primary Distal Renal Tubular Acidosis and Deafness by Mutation of ATP60A4 Gene: Case Report

Nadia Mebrouk^{1*}, Rachid Abilkassem² and Aomar Agadr²

¹Physician Resident in Pediatrics, Children's Hospital, Rabat, Morocco.

²Department of Pediatrics, Military Teaching Hospital Mohammed V, Faculty of Medicine and Pharmacy, University Mohammed V, Rabat, Morocco.

Authors' contributions

This work was carried out in collaboration among all authors. Authors NM and RA designed the study, performed the statistical analysis, wrote the protocol, wrote the first draft of the manuscript, and managed the analyses of the study. Authors NM and RA managed the literature searches. All authors read and approved the final manuscript.

Article Information

DOI: 10.9734/AJPR/2021/v6i430200

Editor(s):

(1) Dr. Emmanouil (Manolis) Magiorkinis, Athens University Medical School, Greece.

Reviewers:

(1) Pritti K Priya, India.

(2) Nataliya Kitsera, Ukraine.

Complete Peer review History: <https://www.sdiarticle4.com/review-history/71954>

Case Study

Received 06 June 2021
Accepted 12 August 2021
Published 19 August 2021

ABSTRACT

Primary distal renal tubular acidosis (dRTA) is a rare genetic disease characterized by distal tubular dysfunction leading to metabolic acidosis and alkaline urine. It is associated with impaired acid excretion by the intercalated cells in the renal collecting duct. dRTA is developed during the first months of life and the main clinical and biologic features are failure to thrive, vomiting, dehydration, anorexia, hyperchloremic non-anion gap metabolic acidosis, hypocitraturia, hypercalciuria and nephrocalcinosis. The disease is caused by defects in genes involved in urinary distal acidification: ATP6V0A4 and ATP6V1B1 for the recessive form, and SLC4A1 for the dominant form. Some dRTA cases due to recessive gene mutations are associated with hearing impairment.

We report the case of two siblings with dRTA, and early-onset SNHL, due to ATP6V0A4 mutations, and whose parents are heterozygous carriers of ATP6V0A4 mutations.

*Corresponding author: Email: nadia.mebrouk@hotmail.com;

Keywords: *Distal renal tubular acidosis; Nephrocalcinosis; Sensorineural deafness ATP6V0A4 gene; Autosomal recessive forms.*

1. INTRODUCTION

Primary distal renal tubular acidosis (dRTA) is a rare genetic disease in which the intercalated cells in the collecting duct fail to secrete the H⁺ required for final urinary excretion of fixed acids. The disease is characterized by the inability to acidify the urine below pH 5.5 during systemic acidemia [1]. Primary dRTA is caused by genetic defects, the most frequently implicated genes being ATP6V1B1 and ATP6V0A4, which cause recessive forms of dRTA and which, respectively, encode the B1 and A4 subunits of the H⁺-ATPase located at the apical surface of the α -intercalated cells. Another gene, SLC4A1, codifies the exchanger Cl⁻/HCO₃⁻ (AE1) placed on the basolateral surface of α -intercalated cells, but its mutations cause a milder form of dRTA that follows an autosomal dominant inheritance [2].

Clinical and biologic features of dRTA include failure to thrive, vomiting and dehydration, loss of appetite, diarrhea or constipation, and polyuria, hyperchloremic non-anion gap metabolic acidosis with inappropriately alkaline urine, and hypokalemia [3]. The association of hypocitraturia and elevated urine calcium excretion leads to nephrocalcinosis and increased risk of urolithiasis [4]. Recessive forms of dRTA may include sensorineural hearing loss (SNHL) [5]. Elhayek et al. found no evidence for an association between early-onset SNHL and the disease gene, and reported that early-onset SNHL was observed in 70% of cases with

ATP6V1B1 gene mutations and in 39% of cases with ATP6V0A4 gene mutations [6].

In this report, we discuss the case of a Moroccan family with recessive form of dRTA associated with precocious hearing loss, and whose genetic testing identified a mutation located in exon 5 of ATP6V0A4 gene. Clinical and molecular diagnosis of dRTA leads to appropriate treatment and prevention of renal failure in affected individuals and provides genetic counseling for families at risk.

2. PATIENTS AND OBSERVATIONS

The first patient is infant KE. The oldest child of a non- consanguineous couple with no particular history, KE was born after a normal pregnancy. Admitted to our service at the age of 45 days for vomiting, acute dehydration, and failure to thrive, her weight was 3200 g (or -2DS) and her height was 50 cm (or -3DS). Her biochemical analysis results are shown in Table 1. Her abdominal ultrasound showed nephrocalcinosis (Fig. 2). At KE's birth, the father and mother were 30 and 22 years old, respectively. The mother is a stay-at-home and the father is a security employee.

The second patient is KE's infant brother TE. Two years younger than KE, TE was admitted to our service at the age of two months for vomiting, acute dehydration, and failure to thrive with a weight of 3300 g (or -2DS), and height of 50cm (or -3DS). His biochemical assessment is shown in Table 1. His abdominal ultrasound showed nephrocalcinosis (Fig. 3).

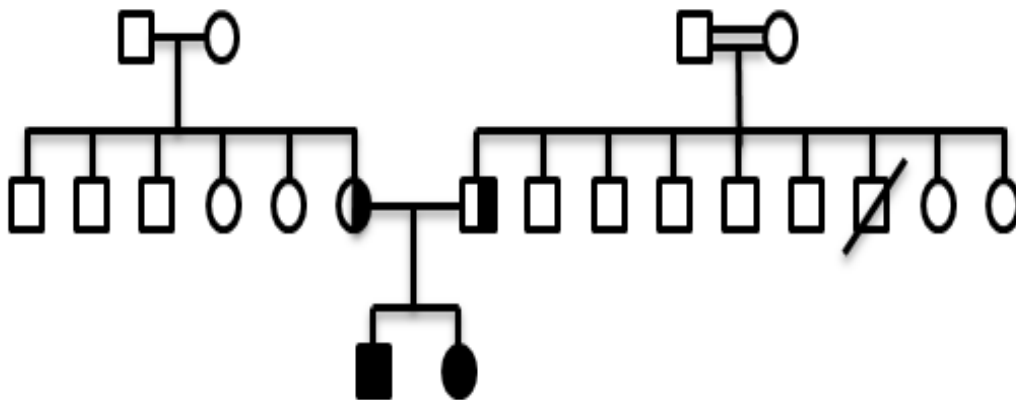

Fig. 1. Family pedigree



Fig. 2. KE Kidney ultrasound: nephrocalcinosis



Fig. 3. KE Kidney ultrasound: nephrocalcinosis

Given their clinical and biological results, the diagnosis of distal tubular acidosis was retained for both patients. The complementary production of an audiogram for KE showed auditory potentials thresholds at -70db on the right and -60db on the left. For patient TE, these thresholds were at -30db on the right and on the left. The children were put on sodium bicarbonate: 2 meq/kg/j and potassium citrate:150 mg/kg/j in three doses per day to start, the dosage being secondarily adapted to the needs, associated with immediate resuscitation measures. The evolution under treatment was favorable with progressive improvement of clinical signs and biological parameters. Hearing impairment is compensated by a hearing aid at the age of 22 months for patient KE.

A genotype assessment of the family was submitted to the Laboratory of Molecular Genetics at the Georges-Pompidou European Hospital in Paris, France. Analysis of the genes responsible for dRTA led to the detection of a nonsense variation in the homozygous state sitting on exon 5 of the A4 subunit of the ATPase proton: *gene ATP6VOA4, Exon 5: variation homozygote c. [387C>A]; [387C>A], p.[(Tyr129Ter); (Tyr129Ter)]*. It is a known mutation that changes tyrosine at position 129 with a STOP codon. The parents are heterozygous carriers of mutations in the same gene.

3. DISCUSSION

The kidney plays a crucial role in the acid-base balance. Indeed, the kidney ensures the homeostasis of the proton concentration and therefore regulates the pH by two mechanisms: the reabsorption of all the bicarbonates filtered by the glomerulus and the excretion of the daily acid charge in the form of ammonia (NH_4^+) and more incidentally, in the form of titratable acidity [7]. The distal secretion of protons takes place in the intermediate cells α , which contain two pumps: an H^+ -ATPase located at the apical pole of the intermediate cells α and which excretes in the tubular lumen the H^+ ions produced in the cell and a chloride exchanger -bicarbonate (AE1) in their basolateral pole which reabsorbs bicarbonate-ions. The H^+ -ATPase is a vacuolar proton pump also located in the inner ear [8,9,10]. Primary dRTA is caused by genetic defects, the most frequently implicated genes

being *ATP6V1B1*, and *ATP6VOA4*, which, respectively, encode the B1 and A4 subunits of the H^+ -ATPase. Another gene, *SLC4A1*, codifies the exchanger $\text{Cl}^-/\text{HCO}_3^-$ (AE1) placed on the basolateral surface of α -intercalated cells, but its mutations cause a milder form of dRTA that follows an autosomal dominant inheritance [2].

Primary dRTA is primarily a childhood pathology. The age of discovery is variable, and depends on the mode of transmission of the disease. Indeed, recessive forms are discovered early, often during the first year of life, while the dominant forms are usually discovered later, in adulthood. Clinically, weight loss is the most common symptom of dRTA in children; it follows chronic acidosis, which causes a reduction in the peak of secretion of growth hormone [11] and disturbs the metabolism of collagen[12]. The most common digestive disorders are anorexia, vomiting, diarrhea and constipation. They are due to metabolic acidosis and also to hypokalemia which causes a decrease in gastrointestinal motility ranging from constipation to the paralytic ileus [13,14]. Dehydration is a multifactorial event. It can be secondary to digestive disorders and / or polyuria. The latter is noted in about 50% of patients with dRTA [15]. Polyuro-polydipsic syndrome is explained by hypercalciuria, but also by a defect in concentration of urine which is constant during this condition [15]. The presence of a conserved diuresis or polyuria during acute dehydration makes it possible to direct the diagnosis towards a tubulopathy, as for our case. The presence of lithiasis or nephrocalcinosis are two complications favored by the association of hypercalciuria, hypocitraturia and an alkaline urinary pH [16]. Regarding the hearing loss, the original disease genetic description made by Karet et al. in 1999 reported that, in families with dRTA and early-onset hearing loss, the putative mutations were identified in *ATP6V1B1* gene, while *ATP6VOA4* gene was implicated in dRTA with normal hearing or at least older-onset hearing impairment [17]. However, subsequent data published by Vargas- Poussou et al. and Elia et al. showed that mutations in either of the two genes might cause early deafness. In the case of our patients, genetic studies showed mutations in exon 5 of the A4 subunit of the ATPase proton gene *ATP6VOA4*. Both patients exhibited hearing loss (moderate-to-severe for KE, and mild for patient TE), which puts them in the special category of cases with early-onset hearing loss with *ATP6VOA4* mutations.

Table 1. Genotype assessment of the family

		Units	Patient KE	Patient TE
Age at diagnosis		months	2	2
Gender			Female	Male
Metabolic acidosis	pH		7.30	7
	[HCO ₃ ⁻]	mmol/l	8	5
Fasting blood glucose		g/l	1.03	1.11
Natremie		mmol/l	141	143
Hypokalemia		mmol/l	3.2	3.2
Hyper chloremia		mmol/l	136	118
Normal plasma anion gap		mmol/l	13.3	15.3
Hypercalcemia		mg/l	120	119
Hypocitraturia		g/l	< 0.16	< 1.16
Normal renal function:	Urea	g/l	0.1	0.2
	Creatinine	mg/l	3	4
Hyperlactatemia		mmol/l	4.28	3.99
Hyperammoniemia		mg/l	1173	1100
High urine pH			9	6.5
Urinary calciuria / creatinine ratio			1.4	1.53

Commonly, alkali supplementation can correct the systemic metabolic defects, restore a normal acid-base balance, improve growth, and stop the progression of nephrocalcinosis. Progression or appearance of SNHL is not prevented by medical treatment. Hearing impairment is treated with hearing aids or cochlear implants when necessary. For each of our patients, treatment with bicarbonate sodium and potassium citrate were initiated at diagnosis. We equipped the older patient with a hearing aid, but her younger sibling was deemed too young to wear one. Patient KE is now learning to talk normally. However, during the follow-up, the two patients achieved normal height with alkali therapy.

4. CONCLUSION

Primary dRTA is the direct result of an inability of the distal tubule to acidify the urine. Urine pH is never lower than 5.5 despite acidemia. It is characterized by its clinical polymorphism; it must be evoked before a hyperchloruremic metabolic acid dose with a urinary pH greater than 5.5, nephrocalcinosis and / or renal lithiasis associated with hypercalciuria and hypocitraturia. Alkalinizing therapy should be started early to achieve near-normal body weight growth, to stop the progression of nephrocalcinosis and to prevent progression to chronic renal failure. Hear aids are used to address SNHL. Genetic testing provides information and aids in family counseling.

CONSENT

As per international standard or university standard, patients' written consent has been collected and preserved by the author(s).

ETHICAL APPROVAL

As per international standard or university standard written ethical approval has been collected and preserved by the author(s).

COMPETING INTERESTS

Authors have declared that no competing interests exist.

REFERENCES

1. Bouzidi Hassan, et al. Inherited tubular renal acidosis. *Annales de biologie clinique*. 2011;69:4.
2. Smith, Annabel N, et al. Vacuolar H⁺-ATPase α 2 subunit: molecular characterization, developmental regulation and localization to specialized proton pumps in kidney and bone. *Journal of the American Society of Nephrology*. 2005;16.5:1245-1256.
3. Mohebibi, Nilufar, Carsten A. Wagner. Pathophysiology, diagnosis and treatment of inherited distal renal tubular acidosis.

- Journal of Nephrology. 2018;31(4):511-522.
4. Nijenhuis Tom, et al. Acid-base status determines the renal expression of Ca²⁺ and Mg²⁺ transport proteins. Journal of the American Society of Nephrology. 2006;17(3): 617-626.
 5. Alexander R. Todd, et al. Hereditary Distal Renal Tubular Acidosis Synonyms: Classic Renal Tubular Acidosis, Type 1 RTA. Gene; 1:2.
 6. Elhayek, Donia, et al. "Molecular diagnosis of distal renal tubular acidosis in Tunisian patients: proposed algorithm for Northern Africa populations for the ATP6V1B1, ATP6V0A4 and SCL4A1 genes." BMC Medical Genetics. 2013 ;14(1):1-10.
 7. Rossert J, Barousse-Nicolet L. Régulation rénale de l'équilibre acide-base. Annales de biologie clinique. 2000;58(6).
 8. Rodríguez-Soriano Juan. New insights into the pathogenesis of renal tubular acidosis—from functional to molecular studies. Pediatric nephrology 2000;14(12): 1121-1136.
 9. Karet Fiona E. Inherited distal renal tubular acidosis. Journal of the American Society of Nephrology. 2002;13(8):2178-2184.
 10. Blanchard A, Poussou R, Houillier P. Exploration des fonctions rénales. Nephrol Ther 2009;5:68-83
 11. Green, Jacob, Gila Maor. Effect of metabolic acidosis on the growth hormone/IGF-I endocrine axis in skeletal growth centers. Kidney international. 2000;57(6):2258-2267.
 12. Abdallah, Jihene Ben, et al. L'acidose tubulaire rénale distale primitive: à propos d'un cas. Annales de Biologie Clinique. 2011 ;69(2).
 13. Hubert P, Ben Jaballah N, Labenne M. Troubles de l'eau et des électrolytes. Encycl Med Chir Pédiatr. 1995 ;4-054.
 14. Azouagh, Ikhlass. L'acidose tubulaire rénale. Diss; 2016
 15. Dechaux, M., and A. Caldas. "Acidoses tubulaires. Nephrol. Progrès en néphrologie pédiatrique. 1993;57-64.
 16. Jequier S, Stoermann Chopard C, Terrier F. Nephrocalcinose et autres calcifications du parenchyme rénal. Encycl Med. Chir. Radiodiagnostic. Urologie. Gynécologie. 2002;34-180-A-10:24.
 17. Escobar, Laura I, et al. Mutations in ATP6V1B1 and ATP6V0A4 genes cause recessive distal renal tubular acidosis in Mexican families. Molecular Genetics & Genomic Medicine. 2016;4(3):303-311.

© 2021 Mebrouk et al.; This is an Open Access article distributed under the terms of the Creative Commons Attribution License (<http://creativecommons.org/licenses/by/4.0>), which permits unrestricted use, distribution, and reproduction in any medium, provided the original work is properly cited.

Peer-review history:

*The peer review history for this paper can be accessed here:
<https://www.sdiarticle4.com/review-history/71954>*