

Development of Comfortable Umbrella with Fan by Using Solar Energy

Hakiki ^a, Hakim Khaula Nurul ^b, Nugroho Yuniarto Wimbo ^b and Hao Liu ^{c*}

^a *Department of Mechanical Engineering, Graduate School, Keimyung University, Daegu, S. Korea.*

^b *Department of Electronics Engineering, Graduate School, Keimyung University, Daegu, S. Korea.*

^c *Faculty of Mechanical Engineering, Keimyung University, Daegu, S. Korea.*

Authors' contributions

This work was carried out in collaboration among all authors. Author H designed and analyzed the mechanical part of the system, and wrote the first draft of the manuscript. Author HKN and author NYW designed electrical circuit and performed simulation. All authors revised and approved the final manuscript.

Article Information

DOI: 10.9734/AJR2P/2021/v5i430171

Open Peer Review History:

This journal follows the Advanced Open Peer Review policy. Identity of the Reviewers, Editor(s) and additional Reviewers, peer review comments, different versions of the manuscript, comments of the editors, etc are available here: <https://www.sdiarticle5.com/review-history/84248>

Original Research Article

Received 22 October 2021
Accepted 27 December 2021
Published 30 December 2021

ABSTRACT

Heat waves often occur during sunny days in tropical regions during summer season, with temperatures sometimes reaching over 42 degrees Celsius. Because overheat waves can cause heatstroke for human beings who work outside, umbrellas are usually used to cut off sunshine to protect them. In the paper, an umbrella prototype is designed, which can drive a fan to provide cooling effect for persons who work outside in tropical regions. The designed umbrella uses solar cell attached on the above surface of the umbrella to convert solar energy into electricity, which is used to drive a fan or charge a battery. Moreover, the battery can also drive the fan when sunshine intensity is weak, or provide a charging port with 5 voltages for portable devices, such as mobile phones. The key component to realize these functions is an electronic control module, which includes charging circuit and discharging circuit. The former increases output voltage from the solar cell to the desired voltage to charge the battery; the latter can control electricity from the battery to drive the DC motor fan, LED indicator, and charging port.

Keywords: charging circuit; discharging circuit; solar system; voltage step-down; voltage step-up.

1. INTRODUCTION

Heat wind is very common in tropical regions, such as Indonesia, in summer season [1]. When heat wave comes, the temperature increases to 42 degrees Celsius sometimes. Such kind of sultry weather makes people rather uncomfortable when they do activities outside [2]. People must take action to protect themselves from sunlight, such as by using umbrellas. In order to prevent these people from getting heatstroke, a small fan is considered to install under the umbrella to reinforce air circulation. Solar energy, as renewable energy, can be converted into electrical energy by using solar cells [3-5] and it may be used to drive the fan positioned under the umbrella [6,7].

The purpose of this paper is to describe how to design a solar system that drives a fan installed in an umbrella. The design is intended to provide wind flow and reduce ambient temperatures [8]. The solar system proposed in the paper includes several solar cells and a rechargeable battery to store electricity energy for usage when sunlight is weak. In this design, the fan will be placed next to the umbrella column, and blades of the fan does not affect umbrella folding [9]. On the other hand, the battery and electronic control module will be placed on the handle of the umbrella so that it could be convenient to control the system.

2. DESIGN OF SOLAR SYSTEM

2.1 Layout Design

The solar panel adhered to cloths of the umbrella is a main power resource in this system, which produces electrical power to turn on a fan installed at the umbrella frame. A switch button is required to control the fan on or off. The fan is driven by a 5 V DC motor. This is enough to provide the airflow. Besides, the solar panel can provide electricity to charge lithium polymer (Li-Po) battery [10] when sunshine is available. The fan is operated by the battery power when the sun does not appear or is not strong, thereby increasing the performance of the system. The battery is located close to the umbrella's handle. Charge/discharge controller is used among the solar panel, the battery, and the fan to regulate the output voltage and to protect the battery from overcharging. Overcharging will cause the battery to explode, resulting in system damage. Fig. 1. shows the total schematic of the system.

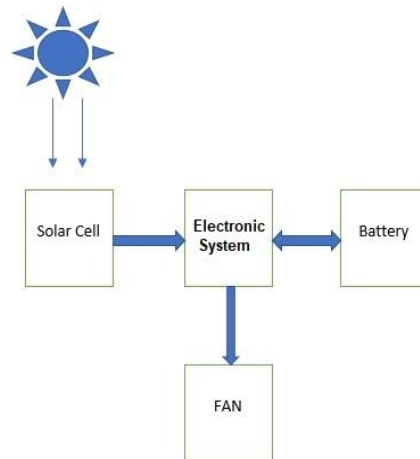

Fig. 1. Schematics of the system

2.2 Design of Electronic Circuit

One of the most challenging tasks of this system is to design and implement an electronic system module, whose functions are listed as below

- i. Battery voltage level indicator
- ii. Charge electricity from the solar cell into the battery
- iii. Discharge function to drive the fan
- iv. Provide 5 voltages for the USB charging port

Consequently, the electronic control system requires two main circuits: power distribution circuit and battery charging control circuit. A battery voltage level indicator and a charging and discharging system are included in the electronic circuit designs, whose electric circuits are shown in Figs 2, 3, and 4, respectively.

The electronic circuit, using generally available low-cost components, is very simple, safe, and economical. The typical target voltage of a 2S Li-Po battery is usually 8.4 V (note that target voltage is not the same as the nominal voltage, which is 7.4 V typically), and Li-Po battery requires a special type of charging mode that uses the CC/CV method (constant current/constant voltage) with 1 C charge grade (1 A for a 1,000 mAh battery). However, charging at a lower than 1 C rate is perfectly safe and will not damage any battery.

The design is optimized for batteries with capacity of 1,000 mAh or higher, and the input power source can be any linear switch-mode

power supply capable of catering an output current of minimum 1,500 mA at 18 V. Normally, a Li-Po battery connected to this circuit will be

charged to 95% of its nominal voltage within 60 minutes and charged up to 100% of its target voltage within two hours thereafter.

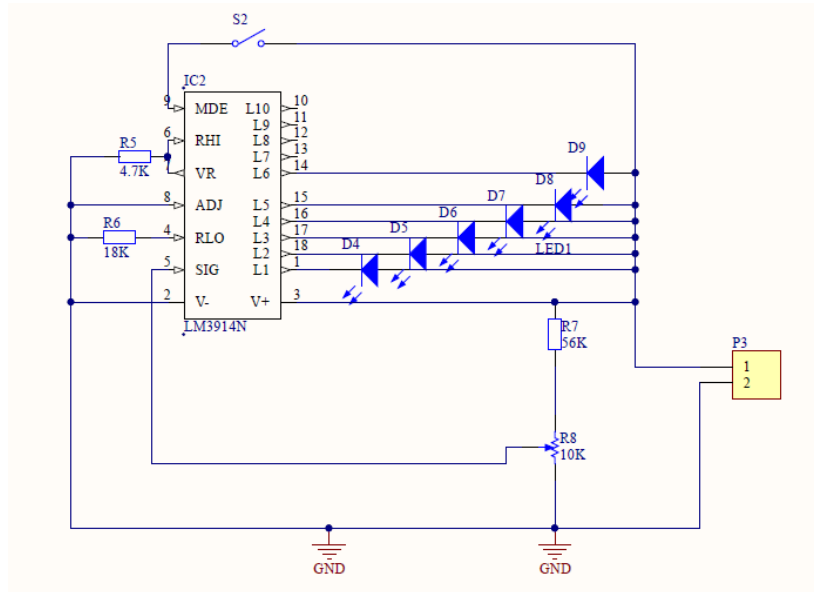

Fig. 2. Battery voltage level indicator circuit

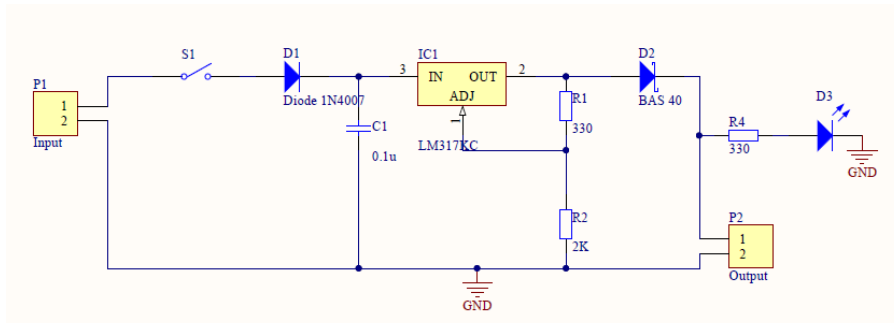

Fig. 3. Schematics of charging circuit

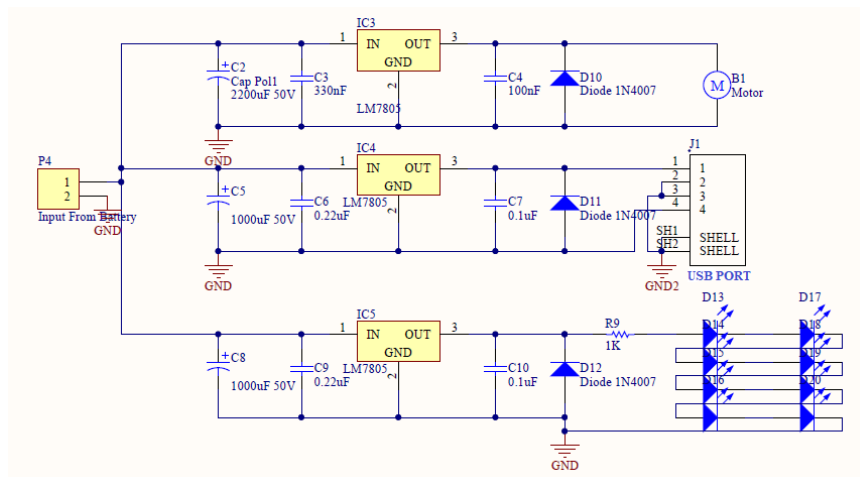

Fig. 4. Schematics of discharging circuit

A popular adjustable three-pin voltage regulator LM317T, in fact, is a perfect electronic component with blend of one perfect constant current source and one constant voltage source, which is why it is used in our design. In electric circuits shown in Figs from 2 to 4, IC1 and R1 set the output limit current while IC2, R2 and P1 set the regulated voltage output. Related capacitors, C1 and C2, are used to increase circuit stability by reducing unwanted noise. The rest of the electronic circuit is one a bunch of visual indicators and their supporting components. LED1 (amber) is the “power-/battery-connected” indicator; LED2 (blue) is the “current flow” indicator, and LED3 (red) is the optional “battery-charged” indicator. The entire circuit can be constructed on a small PCB. All ICs must have heat sinks, and the TO-220 heatsinks should be isolated from other components of the circuit. After construction, feed 18 V to the circuit through DC_IN jack (J1) and adjust P1 to get precisely 8.4 V (± 0.02 V) at the VBAT rail.

solar panels are attached on cloths of the umbrella in the construction process of solar cell. The charging voltage requires more than 8.4 V to provide power for the system, so 6 units of the solar panels with 1.6 volts are installed on the umbrella

3. PERFORMANCE ESTIMATION

3.1 Charge and Discharge Performance

As mention in the previous discussion, battery charger must provide a higher voltage than the voltage of battery so the charger voltage is around 8.4 V for a Li-Po 7.4 V 3200 mAH battery. Output voltage of the regulator LM317T depends on the resistances of resistors R1 and R2 in Fig. 3, which can be calculated according to Eq. (1).

$$V_{out} = V_{ref} \left(1 + \frac{R2}{R1} \right) \quad (1)$$

In our design, $V_{ref} = 1.25$ V, $R1 = 330 \Omega$, and $R2 = 2$ K Ω , thus $V_{out} = 8.82$ V, which satisfies charging condition.

The performances of the designed electronic control system can be investigated via simulation. Fig. 5 illustrates the simulation schematic of charging circuit.

Based on simulation circuit shown in Fig. 5, the simulation result shows the output voltage of charger is 8.92 V, which is a little bit higher than the above calculated value, 8.82 V. This output voltage is used to charge the Li-Po battery with 7.4 V and capacity of 3200 mAH. The charging time of battery can be calculated by the following Eq. (2).

$$T_c = \left(\frac{C_B}{I_c} \right) * 60minute \quad (2)$$

T_c = Charging time

C_B = Battery capacity

I_c = Charging current from charger

The calculation result shows that the completely charging battery needs 101.58 minutes or 1 hour 41.58 minutes. After fully charged, the battery can run until allowable cutoff voltage. Moreover, according to motor datasheet, the power of the fan motor equals 7.5 Watt. Therefore, the running time of the fan motor can be calculated through the below Eq. (3).

$$T_R = \frac{C_B}{P_M} \quad (3)$$

T_R = Running time of battery

P_M = Power of motor

The calculation result shows 3 hour 13 minutes, which means the system fan can run at least 3 hours by using power from battery.

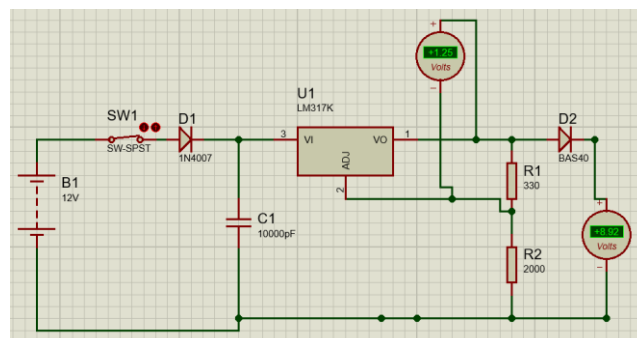

Fig. 5. Simulation schematic of charging circuit

3.2 Performance of Airflow

The law of energy conservation states that energy cannot disappear and it is only converted from one form to another form. In our designed system, mechanic energy transformed from electric energy of the fan motor becomes kinetic energy of airflow [11,12]. The shaft torque applies to blades, and then the rotation of the fan generates airflow. The following figure shows fan operation system.

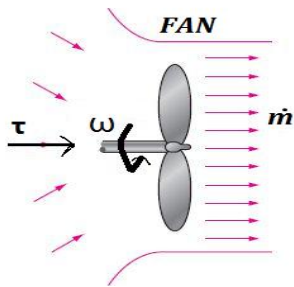

Fig. 6. Schematics of fan work system

The mechanical efficiency (η) of the fan is the ratio of the output mechanical energy to the input electrical energy, which can be written as Eq. (4).

$$\eta = \frac{W_{out}}{W_{in}} = \frac{P_{out}}{P_{in}} = \frac{0.5\dot{m} v^2}{P_{in}} \quad (4)$$

where P_{in} is power input. In this case, the efficiency selected between 0.6 - 0.7. The mass flow (\dot{m}) is defined as airflow through fan blades as Eq. (5).

$$\dot{m} = \rho v A \quad (5)$$

where ρ is air density (kg/m^3), v is velocity of airflow (m/s), and A is cross-section area of circle of fan (m^2).

The relation among the torque of fan (T) in Nm, the angular velocity (ω) and the power supplies (P) in watt is expressed as Eq. (6).

$$P = \omega T = \pi n T / 30 \quad (6)$$

The angular velocity can be written as n in RPM (revolution per minute).

3.3 Calculation Result of Airflow Performance

Fig. 7. shows linear relation between the input power and RPM of the fan motor. Fig. 8.

indicates the relation between the airflow velocity and the power capacity supplied. More power is required for greater airflow velocity. Fig. 9 illustrates the variation of the airflow velocity with the angular velocity of fan motor. Higher rotational speed could improve cooling effect for persons, but it would cause more vibration and noise, which makes them uncomfortable.

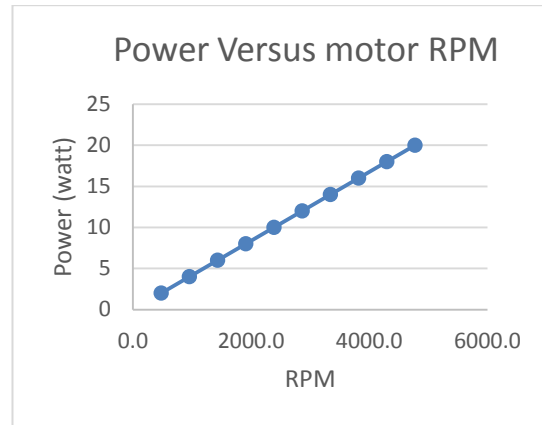

Fig. 7. Relation of power and motor RPM

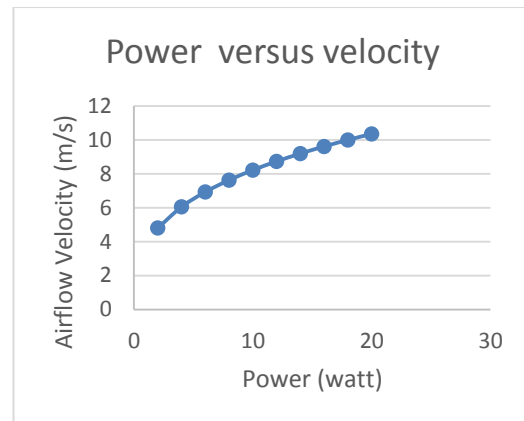

Fig. 8. Relation of power and airflow velocity

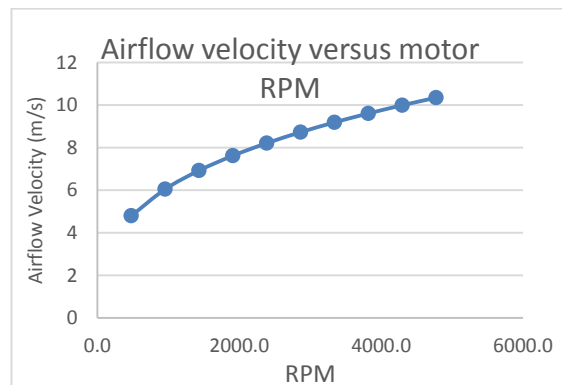

Fig. 9. Relation of airflow velocity and motor RPM or RPM

4. CONCLUSION

A comfortable umbrella has been designed in the paper, which contains an electronic control system, a fan motor, a battery and six solar cells. The umbrella can collect solar energy in sunny days and charge electricity into the battery which provides power to the fan motor in order to generate airflow for people outside in tropical regions. The next work is to optimize the prototype umbrella designed in the paper.

COMPETING INTERESTS

Authors have declared that no competing interests exist.

REFERENCES

1. Haruka K, Takashi A, Tetsu K, Anhang RT, Hiroshi M. Thermal storage effect of radiant floor cooling system using phase change materials in the hot and humid climate of Indonesia. *Building and Environment*. 2022;207(B).
2. Fanger P O. Assessment of man's thermal comfort in practice. *British Journal of Industrial Medicine*. 1973;30: 313-324.
3. McFarland EW. Solar energy: setting the economic bar from the top-down. *Energy and Environmental Science*. 2014;7(3): 846–854.
4. Renewable Energy Policy Network for the 21st Century. *Renewable 2011 Global Status Report*. 2011; 1:4.
5. Michael B. *The Solar Electricity Handbook – 2021 Edition: A simple, practical guide to solar energy – designing and installing solar photovoltaic systems*. Greenstream Publishing; 2021.
6. Li Q, Naing V, Hoffer JA, Weber DJ, Kuo AD, Donelan JM. Biomechanical energy harvesting: apparatus and method. *Proceedings IEEE International Conference on Robotics and Automation, ICRA*; 2008.
7. U.S. Department of Energy. *Improving Fan System Performance*; 2003. Available:<https://www.nrel.gov/docs/fy03osti/29166.pdf>
8. Alnasir Z, Kazerani M. An analytical literature review of stand-alone wind energy conversion systems from generator viewpoint. *Renewable and Sustainable Energy Reviews*. 2013;28(C):597-615.
9. Paul El Khoury, Yara Saadeh, Charbel Azzi, Samer Bu Jawdeh and Ramsey F. Hamade. *Eco-Brella: prototype development of the umbrella as harvester of solar and wind energies*. *International Journal of Sustainable Manufacturing*. 2014; 3(3):207-228.
10. What's the Best Battery? Available:http://batteryuniversity.com/learn/article/whats_the_best_battery
11. Bruce R, Munson, Donald F, Young, Theodore H, Okiishi. *Fundamentals of fluid mechanics*. 2nd ed. John Wiley & Sons Inc; 1996.
12. Budynas, RG, Nisbett K. *Shigley's mechanical Engineering design*. 9th ed. MC Graw-Hill publishers, New York; 2011.

© 2021 Hakiki et al.; This is an Open Access article distributed under the terms of the Creative Commons Attribution License (<http://creativecommons.org/licenses/by/4.0>), which permits unrestricted use, distribution, and reproduction in any medium, provided the original work is properly cited.

Peer-review history:
The peer review history for this paper can be accessed here:
<https://www.sdiarticle5.com/review-history/84248>