



Analysis and Evaluation of Specific Absorption Rate of GSM Signal in Port Harcourt, Nigeria

Promise Elechi^{1*}, Sunny Orike¹ and Promise Agugharam¹

¹*Department of Electrical Engineering, Rivers State University, Port Harcourt, Nigeria.*

Authors' contributions

This work was carried out in collaboration among all authors. Author PA designed the study, performed the statistical analysis, wrote the protocol and wrote the first draft of the manuscript. Authors PE and SO managed the analyses of the study. Author PE managed the literature searches. All authors read and approved the final manuscript.

Article Information

DOI: 10.9734/JERR/2019/v5i416934

Editor(s):

- (1) Dr. Pierre-Olivier Logerais, Associate Professor, Department of Energy Systems, Université Paris-Est Créteil, France.
- (2) Dr. Leandro A. Pasa, Professor, Campus Medianeira da Universidade Tecnológica Federal do Parana, Brazil.

Reviewers:

- (1) Julie Ogbulezie, University of Calabar, Nigeria.
 - (2) Aliyu Bhar Kisabo, National Space Research and Development Agency, Nigeria.
- Complete Peer review History: <http://www.sdiarticle3.com/review-history/49579>

Original Research Article

Received 30 March 2019
Accepted 15 June 2019
Published 21 June 2019

ABSTRACT

There is a growing concern in the world that residents close to GSM base station facilities are exposed to electromagnetic radiation which causes different health illness like cancer, leukemia, memory lost, dizziness, fatigue, etc. This study puts to rest the position on the effect of radiofrequency (RF) radiation from GSM masts on human health. In this research work, the evaluation and assessment of radio frequency radiation in five selected mobile base stations facilities in Obio/Akpor Local Government of Rivers State, Nigeria were carried out using an EMF meter for measurement of Electric field. The measurements of the radio frequency radiation with the EMF meter was conducted from 0 – 300m away from the selected base transceivers stations facilities of the selected telecommunication operators (MTN, Globacom and Airtel) in Nigeria. The data obtained from the research were analyzed using Specific Absorption Rate formula to establish whether with time exposure to RF radiation will have negative impact on human health. The normal specific absorption rate (SAR) and the Power Density for the general public whole body was assessed from the measured electric field strength and the results were compared with that of International Commission on Non Ionization Radiation Protection (ICNIRP). The results showed that the average amount of SAR for the selected five base transceiver station (BTS) facilities were within the range of 0.0037 W/kg – 0.0084 W/kg and the power density 1.5183 W/m² – 9.5083 W/m². These values are lower than the recommended limit by ICNIRP which is 0.08w/kg for the

*Corresponding author: Email: elechi.promise@ust.edu.ng;

human body. This study has shown that there is inconsequential effect on human health because the non-ionizing electromagnetic energy has no sufficient energy to affect any part of human body for the residents living close to the selected BTS facilities of the various telecommunication providers.

Keywords: Electromagnetic field; BTS; SAR; ICNIRP.

1. INTRODUCTION

Telecommunication facilities require a network of towers, antennas and associated structure to host the network devices. Habitually, slope tops are great areas since they empower signals to be picked up from and transmitted to an expansive zone. With increasing demand for mobile telephone services as a result of high population and technology awareness, there has been a significant increase in the demand for such facilities. Today in Nigeria, masts are erected even in the compounds of living homes with little or no consideration of the effects on the health of the people. This study is to find out the amount of radiation emanating from these BTS facilities and check immediate and long-term impact if there are any on the environment and the people living very close to these facilities.

This study evaluates the electromagnetic field strength of selected base stations of the telecommunication service providers (MTN, Globacom and Airtel) within some communities (Rumuolumeni, Rumuchakara, Akwaka, Woji and Elioizu) in Obio/Akpor local government of Rivers State. The study is aimed at analyzing and evaluating the specific absorption rate (SAR) due to GSM BTS signals and check if they meet International Commission on Non-Ionization Radiation Protection (ICNIRP) standards and limit.

The result of this research work can serve as a working document for imminent radio frequency (RF) radiation from the selected BTS facilities because there has not been any research carried out in the mapped-out area to the knowledge of the researcher.

1.1 Literature Review on Electromagnetic Field from Base Transceiver Station Facilities

Both positive and negative electric charges generate electric field in a stable or moving situation. The current caused by moving charges is main source of magnetic field. Time varying electric and magnetic fields are accompanied to each other to produce an electromagnetic field.

After that, electromagnetic waves which radiate from BTS facilities are produced by these time varying electromagnetic fields [1]. Related work [2] in their study observed that the electromagnetic radiation emitted by mobile phone base stations was measured in terms of electric field strength as a function of distance. The measured values were used to calculate specific absorption rate of the skin and brain tissue to assess the health risks. Certain directions were found to be safer than the other directions. Results has shown that the values of the SAR for the eight base stations selected for the study were within the range of 0.00010 W/kg to 0.0012 W/kg Also, [3-4], in their studies showed that long term exposure to radiation from the base stations causes different ailments such as cancer cases, prostate, breast and lungs cancer. Other forms of ailment caused by mast location as reported are that of leukemia, lymphoma and hematopoietic which damaged blood cells, untimely death, fever, migraine as a result of vibration and contamination of environment due to the pollution from generators. They found out that there is a substantial relationship between mast location and health of the inhabitants [4]. Santini et al. [5] confirmed further the effect of telecommunication mast on the health of people of United Kingdom in which they observed that mast operators around the Northern United Kingdom were inquired by the inhabitants and local authority to clear their telecommunication masts due to the negative impacts on the inhabitants. They reported twenty-seven (27) cases of collapsed masts tower as a result of weather problem.

2. METHODOLOGY

2.1 Materials and Methods

A detailed procedure was followed to determine the existence of the masts inside residential areas. This study emphasizes a lot on the quantity of electromagnetic radiation emanating from these GSM base transceiver stations (BTS) in Obio-Akpor local government area. The materials and instruments used in the study are Measuring Tape, Stop Watch, TES – 593 Electromog

(EMF) Meter, Data Recording Sheet, GPS Meter and Mobile Phone.

The Electrosmog meter by TES Electrical Electronic Corporation USA (model TES-593 serial No 006P 9V- 090200180) was used for the measurements. The device is a handheld broadband meter for detecting high-frequency radiation in the range from 50 MHz - 3.5 GHz. It is a non-directional digital 3-axis radio frequency (RF) handling meter. It is an effective meter for digital RF signals and equally very sensitive (2 V/m to 100 V/m).

2.2 Measurement Approach

For each of these locations, measurements from GSM BTS facilities were carried out in five

different locations in Obio/Akpor LGA. The data were collected from the three major telecommunication operators (MTN, Globacom and Airtel) masts to ascertain the amount of radiations emitted from these base stations. The masts are located at Rumuolumeni, Akwaka, Rumuchakara, Elioazu and Woji all in Obio/Akpor Local Government of Rivers State, Nigeria. For each of these locations the measurements of electromagnetic radiation were taken at 50m, 100m, 150m, 200m, 250m and 300m every 10 minutes.

In order to collect accurate and reliable data the three telecoms companies (MTN, Globacom and Airtel) visited with different locations are shown Table 1.



Fig. 1. Picture of MTN Mast visited at Rumuolumeni



Fig. 2. Picture of airtel mast visited at Akwaka



Fig. 3. TES – 593 Electromog (EMF) meter

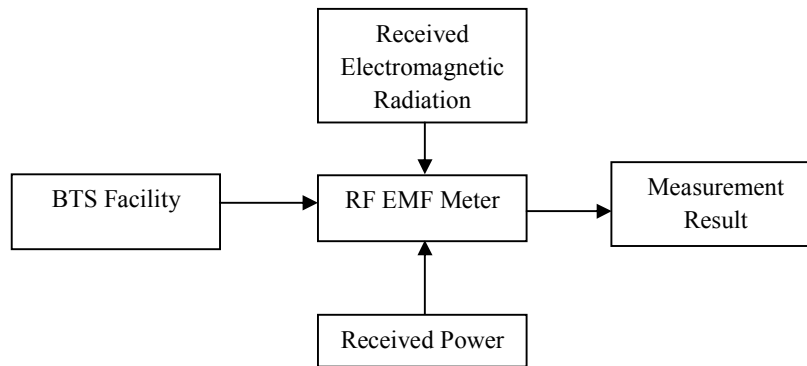

Fig. 4. Block diagram of measurement

Table 1. Measurement locations and their coordinates

S/N	SITE ID	LOCATION	COORDINATE (Degree)
1	MTN 4232	Rumuolumeni – 3 Ohiamati street, Police post bus stop.	Longitude: 7.05659099 Latitude: 4.785383159
2	IHS_PHC 116	Choba – Rumuchakara Road, Choba	Longitude: 6.995768598 Latitude: 4.830232823
3	IHS_PHC161	Rumuodumaya – Akwaka Road	Longitude: 7.0364968 Latitude: 4.8716169
4	MTN 3456	Eliozu – New Eliozu Road	Longitude: 6.987324968 Latitude: 4.905511315
5	PAR 174	Woji – Abec Road, off ALCON	Longitude: 7.061797107 Latitude: 4.872241849

2.3 SAR Evaluation and Standards

Specific Absorption Rate (SAR) is the quantity of energy which the human body can absorb when exposed to radiofrequency electromagnetic field. SAR computation was derived from Maxwell's equations. E and H are first determined analytically or numerically from Maxwell's equations. The unit of SAR is Watt per kilogram. It can be calculated from E using equation (1) [6]. An EMF meter detects the electric field strength E and converts it into magnetic field strength H and power density S. The meter measures E along three different axes but can also take readings of all the Es' at the same time when set to the triaxial mode of operation. The electric field (E), the magnetic field (H) are all related to power density (S) expressed in Watts per meter squared (W/m²) as shown in the equation below.

$$S = EH = \frac{E^2}{377} = 377\Omega H^2 \tag{1}$$

where 377 Ω is the characteristic impedance of vacuum.

$$SAR = \frac{\sigma/E^2}{\rho} \tag{2}$$

where

- σ is the electrical conductivity (S/m)
- E is the electric field strength (V/m)
- ρ is mass density of the medium (kg/m³)

Using the electric fields, the dissipated power density, S in any tissue can also be calculated using the following equation:

$$S = \sigma|E|^2 = \rho SAR \tag{3}$$

This also implies that;

$$SAR = \frac{\sigma/E^2}{\rho} = S \tag{4}$$

Equation (2) is a point equation, so it is often called the resident SAR. The space-average SAR for a body or a part of the body is obtained by calculating the resident SAR at each point in the body and averaging over the part of the body being considered.

3. RESULTS AND DISCUSSION

To analyze the results, the specific absorption rate (SAR) was first determined and the graphical analysis in other to establish whether exposure to GSM base station has effect or no effect on human health for a long period of time. All the telecom service providers (MTN, Globacom and Airtel) antennas were made to radiate 1800 MHz; they have the following specifications Globacom, MTN and Airtel have down link frequency of 1820 – 1835 MHz, 1835 – 1850 MHz, 1850 – 1865 MHz, uplink frequency of 1725 – 1740 MHz, 1740 – 1755 MHz and 1756 – 1770 MHz, respectively. Shown in Figs. 5 and 6 below are the variations of SAR and power density with distance for all the 5 base station sites used for this study. Summarized in Figs. 7 and 8 are the average SAR and power density values for the 5 base stations for site comparison.

Table 2. Summary of ICNIRP's general public safety guidelines for limiting radiation exposure and SAR

Frequency	E-Field (V/m)	H-Field (A/m)	Power density (W/kg)	Whole body SAR (W/kg)	Localized (head) (W/kg)
400-2000MHz	1.375f ^{1/2}	0.003f ^{1/2}	f/200	0.08	2
2-300 GHz	61	0.16	10	0.08	2

Table 3. Summary of average SAR and power density at distance 50m – 300m

Site	Network provider	SAR	Power density
Rumuchakara	MTN	0.0066	4.9466
Awaka	Airtel	0.0037	4.1083
Woji	Globacom	0.0084	9.5083
Rumuolumeni	MTN	0.0043	1.5183
Eliozu	Globacom	0.0052	2.5267

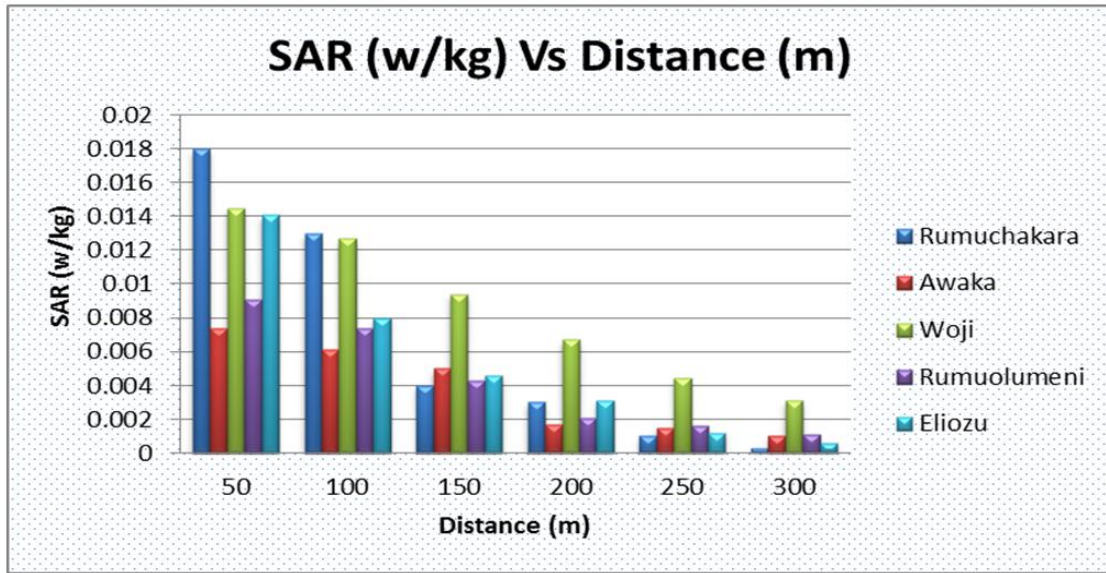

Fig. 5. SAR versus distance from the five selected BTS stations

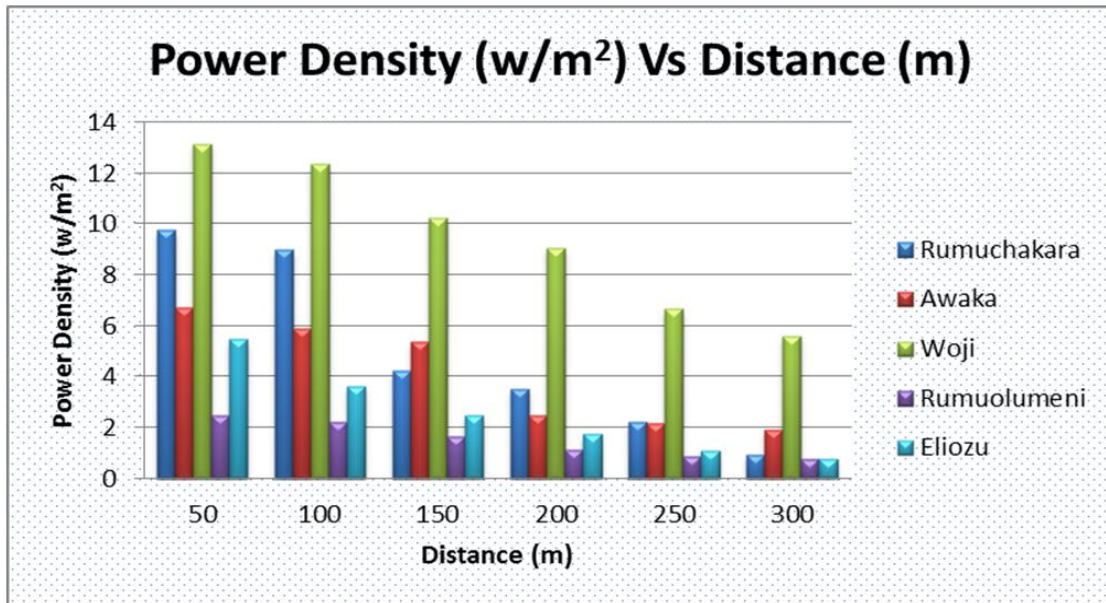

Fig. 6. Power density versus distance from the five selected BTS stations

3.1 Compared Result and ICNIRP Standards

In Figs. 9 and 10, the highest radiation levels were observed at a distance of 50 m, 100 m and 150m from sites 1-5 respectively and the SAR values in W/Kg ranged from 0.0037 W/kg – 0.0084 W/kg and power density ranged from 1.5183 W/m² – 9.5083 W/m² which are quite lower than the maximum safety standard

limit (0.08 W/kg for whole body exposure) set by the International Commission on Non-ionizing Radiation protection (ICNIRP). The ICNIRP standards state that for any frequency between 400-2000MHz used, it must be divided by 200 (f/200) to determine the required limit for power density. The Telecommunication service providers (MTN, Globacom and Airtel) antennas radiate between 900 – 1800 MHz; this implies

that the limit for power density for this research work is:

$$f = 1800$$

$$f/200 = 1800/200 = 9.00 \text{ W/m}^2$$

From Fig. 10, it can be observed that the highest power density came from the Woji base station (9.5083 W/m²) which is slightly above 9.00 W/m² with a difference of 0.5083 W/m².

3.2 Root Mean Square Deviation

The root-mean-square deviation (RMSD) or root-mean-square error (RMSE) is a frequently used measure of the differences between values (test and population values) predicted by a model or an estimator and the values really observed. It serves to aggregate the extents of the errors

in forecasts for different times into a single measure of present power [7]. The Root Mean Square Deviation is given by [8]:

$$\text{RMSD} = \sqrt{\frac{\sum_{i=1}^N (x_i - \hat{x}_i)^2}{N}} \tag{5}$$

where:

x_i = the actual observation values

\hat{x}_i = the estimated or forecasted standard limit given value

N = the number of data entry

Table 4 shows that even with the fluctuations of radiation the root mean square deviation values for specific absorption rate and the power density for the different locations falls within the ICNIRP set standards.

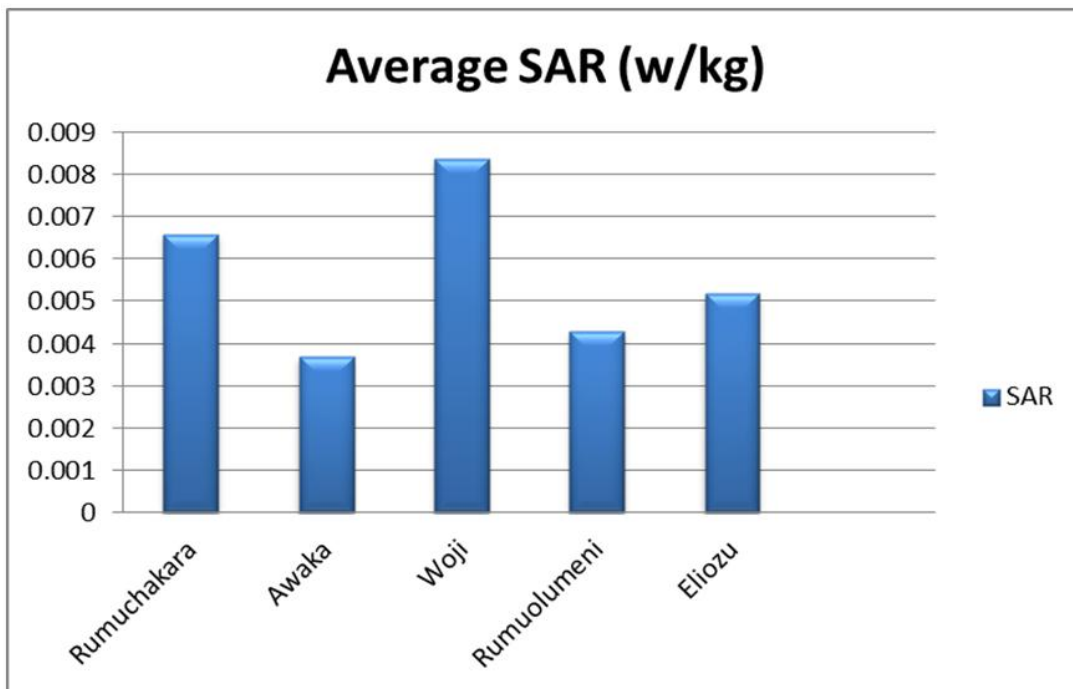

Fig. 7. Average SAR from the five selected BTS stations

Table 4. Summary of RMSD for SAR and power density

Location	RMSD (SAR)	RMSD (Power Density)
Woji	0.071654	2.7969
Elioze	0.074877	6.67188
Awaka	0.076257	5.2681
Rumuolumeni	0.072794	7.5104
Rumuchakara	0.073746	5.2294

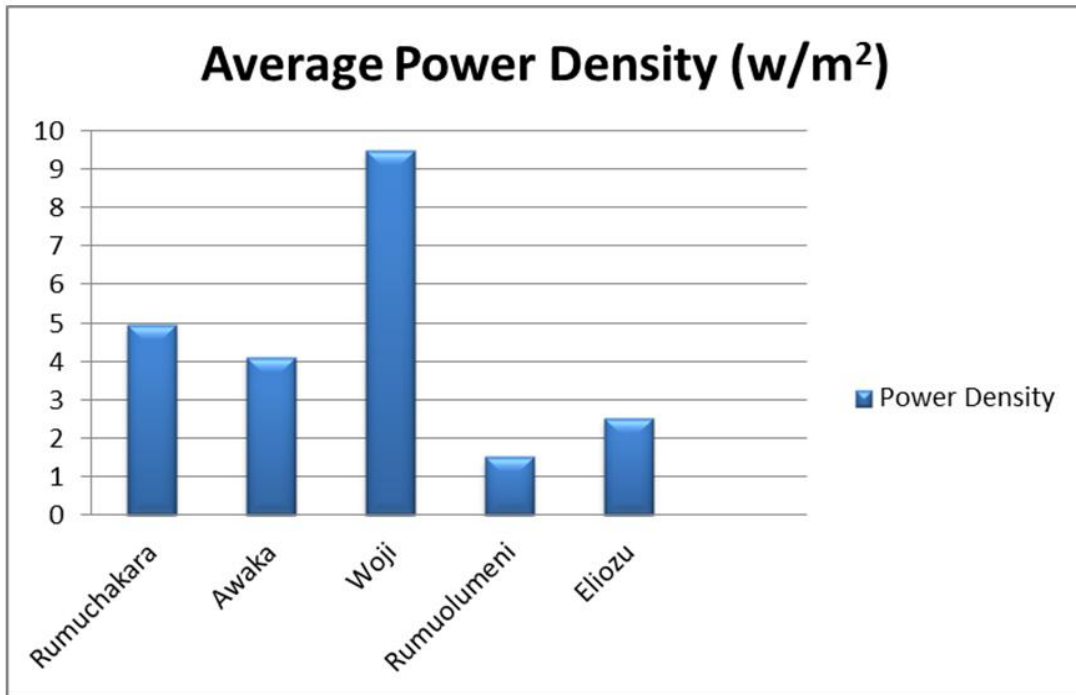

Fig. 8. Average power density from the five selected BTS stations

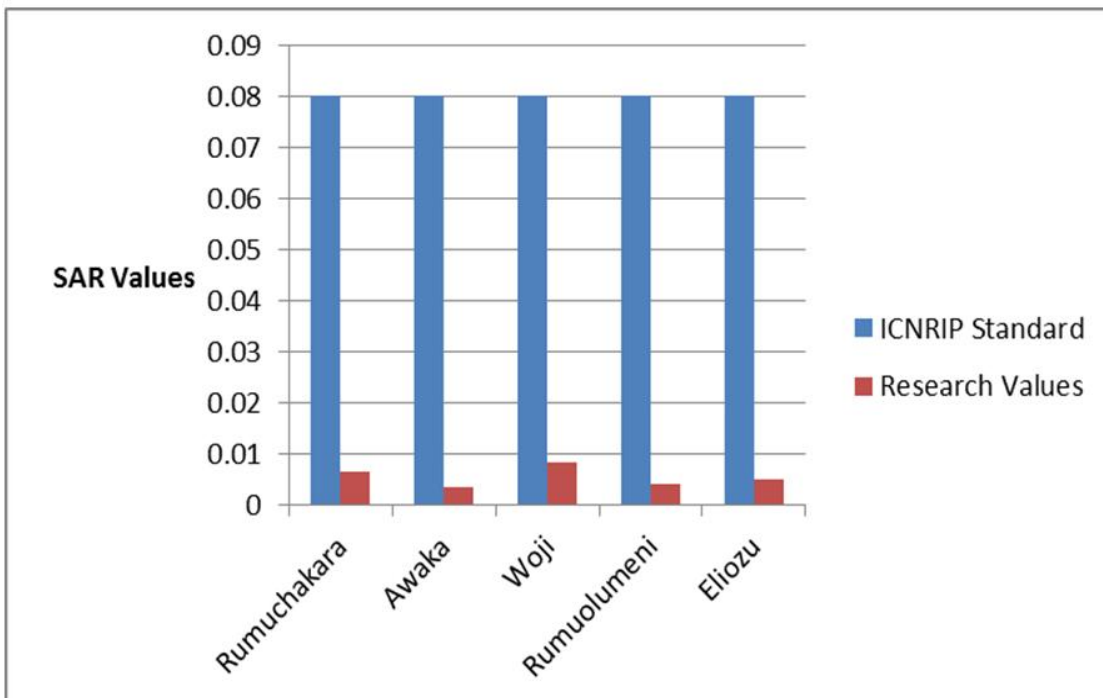

Fig. 9. ICNIRP SAR standards and research values

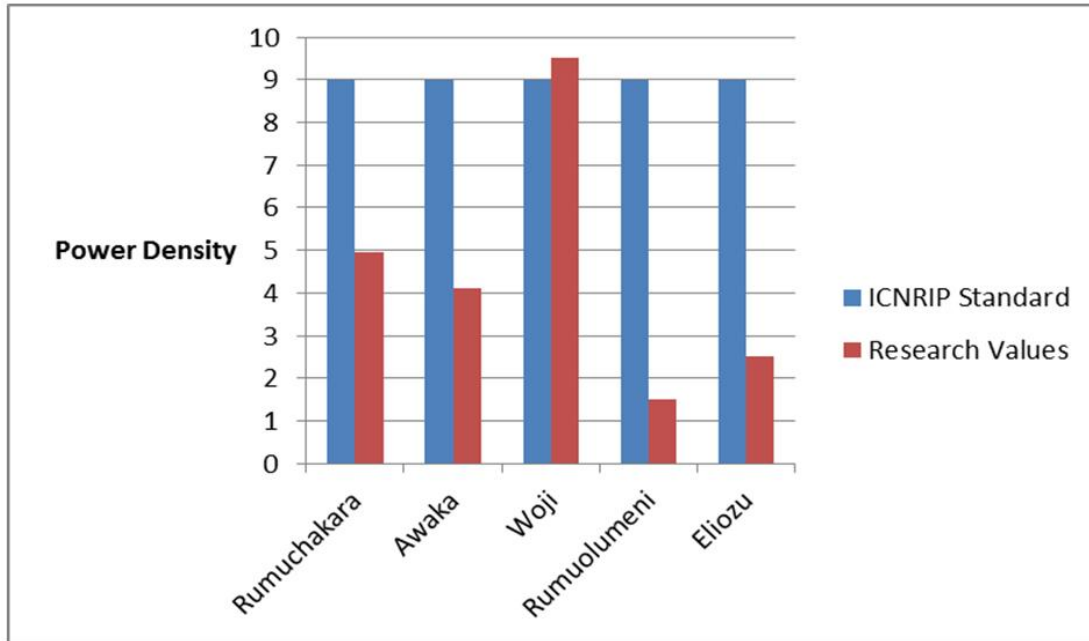

Fig. 10. ICNIRP power density standard and research values

4. CONCLUSIONS

The electromagnetic radiation emitted by mobile phone base stations was measured in terms of electric field strength as a function of distance. The measurements were done in five BTS stations belonging to three different GSM network (MTN, Globacom and Airtel) operators in the study locations. The measured values were used to calculate specific absorption rate of the whole-body tissue and power density to assess the health risks. Certain directions were found to be safer than the other directions. Results show that the values of the SAR and power density for the five base stations selected for the study are within the range of 0.0037 W/kg to 0.0084W/kg and 1.5183W/m²– 9.5083W/m² respectively. These values are quite lower than the limit by International Commission on Non-ionizing Radiation Protection (ICNIRP) which is 0.08 W/kg [9,10,11] for the whole-body average SAR. This demonstrates that there is no significant health risk for the residents that stay in the vicinity of the selected base stations for the various mobile service provider of the area.

COMPETING INTERESTS

Authors have declared that no competing interests exist. The products used for this research are commonly and predominantly use

products in our area of research and country. There is absolutely no conflict of interest between the authors and producers of the products because we do not intend to use these products as an avenue for any litigation but for the advancement of knowledge. Also, the research was not funded by the producing company rather it was funded by personal efforts of the authors.

REFERENCES

1. Cheng D. Field and wave electromagnetic (2nded.), London: Prentice Hall; 2002.
2. Isabona J, Ojuh OD. Experimental assessment of specific absorption rate using measured electric field strength in benson idahosa university and environs. American Journal of Modern Physics. 2015;4(2):92-96. DOI: 0.11648/j.ajmp.20150402.16
3. Abdel Rassoul G, Abou El, Batanouny, Salem ME. Neuro toxicology: Neuro-behavioral effects among inhabitants around mobile phone base stations. 2007;434-440.
4. Elechi P, Orike S, Ekanem IA. Assessment and modelling of GSM signal propagation in Uyo, Nigeria. European Journal of Engineering Research and Science. 2017;2(11):1-10.

- Available:<http://dx.doi.org/10.24018/ejers.2017.2.11.502>
5. Onifade AO, Ikotun SA, Opejin AO, Ibraheem BA. Health implication of mast location in urban area. A Case Study of Egbeda L.G.A. of Oyo State; 2011.
 6. Santini R, Santini P, Danze JM, Le Ruz P, Seigne M. Investigating on the health of people living near mobile telephone relay station. Pathol Bol, Paris. 2002;50(6):369-373.
 7. Thors B, Strydom M, Hansson B, Meyer F, Krkkinen K, Zollman P, Ilvonen S, Tornevik C. Estimation of SAR and compliance distance related to RF exposure from mobile communication base station antennas. IEEE Trans. Electromagnet. Compact. 2008;50(4):837-848.
 8. Hyndman RJ, Koehler AB. Another look at measures of forecast accuracy. International Journal of Forecasting. 2006; 22(4):679–688. DOI: 10.1016/j.ijforecast.2006.03.001
 9. Tsay RS. Analysis of financial time series. John Wiley & Sons; 2005. [ISBN 0-471-690740]
 10. International Commission on Non-ionization Radiation Protection [ICNIRP]. Guidelines for limiting exposure to time-varying electric, magnetic and electromagnetic fields (up to 300 GHz). Health Physics. 1998;74:494-522.
 11. Elechi P, Otasowie PO. Path loss prediction model for GSM fixed wireless access. European Journal of Engineering Research and Science. 2016;1(1):1-4.

© 2019 Elechi et al.; This is an Open Access article distributed under the terms of the Creative Commons Attribution License (<http://creativecommons.org/licenses/by/4.0>), which permits unrestricted use, distribution, and reproduction in any medium, provided the original work is properly cited.

Peer-review history:
The peer review history for this paper can be accessed here:
<http://www.sdiarticle3.com/review-history/49579>